

# Kawasaki™

## **15-AMP 10" COMPOUND MITER SAW INSTRUCTION MANUAL**

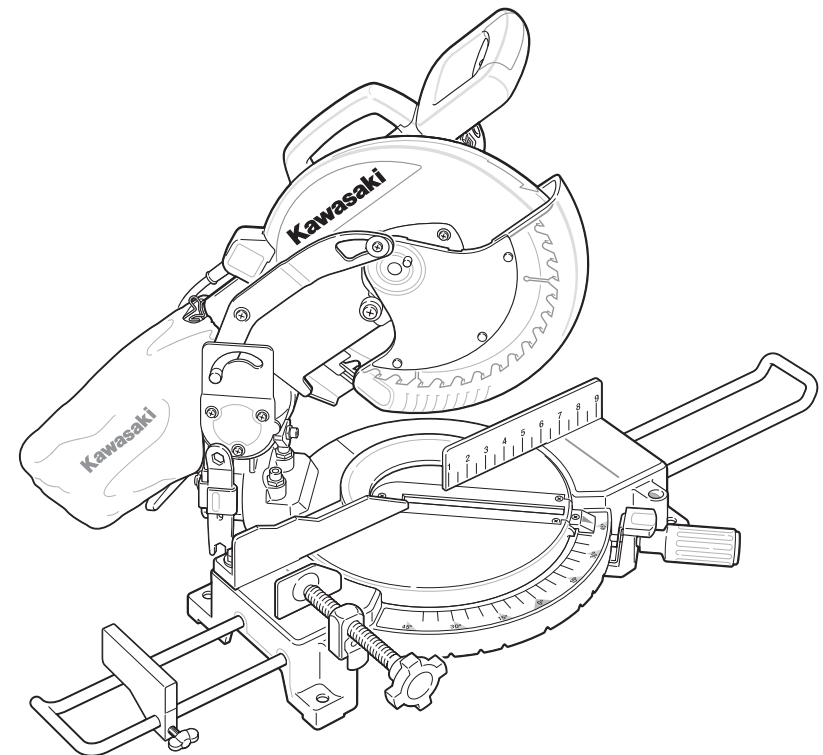

THIS MANUAL CONTAINS IMPORTANT INFORMATION REGARDING SAFETY, OPERATION, MAINTENANCE AND STORAGE OF THIS PRODUCT. BEFORE USE, READ CAREFULLY AND UNDERSTAND ALL CAUTIONS, WARNINGS, INSTRUCTIONS AND PRODUCT LABELS. FAILURE TO DO SO COULD RESULT IN SERIOUS PERSONAL INJURY AND/OR PROPERTY DAMAGE.

IF YOU SHOULD HAVE ANY QUESTIONS OR EXPERIENCE A PROBLEM WITH YOUR ALLTRADE PRODUCT, DO NOT RETURN THIS PRODUCT TO THE STORE. PLEASE CALL OUR CUSTOMER SERVICE DEPARTMENT AT **1-800-590-3723**. BEFORE YOU CALL, HAVE THE FOLLOWING INFORMATION AVAILABLE: MODEL No., DATE PURCHASED AND STORE LOCATION. AN ALLTRADE REPRESENTATIVE CAN RESOLVE YOUR PROBLEM OVER THE PHONE. IF YOU WOULD LIKE TO MAKE A SUGGESTION OR COMMENT, GIVE US A CALL OR EMAIL US AT: [INFO@ALLTRADETOOLS.COM](mailto:INFO@ALLTRADETOOLS.COM). YOUR FEEDBACK IS VITAL TO US.

**FOR CUSTOMER SERVICE  
POUR LE SERVICE APRÈS VENTE  
OU DU CONSOMMATEUR**

**PARA EL SERVICIO  
PARA EL CONSUMIDOR**

**1-800-590-3723**

Printed in China



87-1904-60957

KAWASAKI™ IS A TRADEMARK LICENSED BY KAWASAKI™ MOTORS CORP., U.S.A., WHICH DOES NOT MANUFACTURE OR DISTRIBUTE THIS PRODUCT. CONSUMER INQUIRES SHOULD BE DIRECTED TO:

©COPYRIGHT 2007 ALLTRADE TOOLS, LLC.  
1431 VIA PLATA  
LONG BEACH, CA 90810-1462 USA  
840378\_15-amp 10" compound miter saw\_Rev 5/17/07

## TABLE OF CONTENTS

<b>CONGRATULATIONS!</b> .....	2
<b>INTENDED USE</b> .....	2
<b>SECTION ONE</b>	
GENERAL SAFETY RULES – FOR ALL ELECTRIC POWER TOOLS .....	2
RECOGNIZE SAFETY SYMBOLS, WORDS AND LABELS .....	3
IMPORTANT SAFEGUARDS .....	4
WORK AREA .....	4
ELECTRICAL SAFETY .....	5
PERSONAL SAFETY .....	5-6
TOOL USE AND CARE .....	6
SERVICE .....	7
<b>SECTION TWO</b>	
SPECIFIC SAFETY RULES AND/OR SYMBOLS .....	7
IMPORTANT SAFETY RULES FOR MITER SAWS .....	7-10
SYMBOLS .....	11
<b>SECTION THREE</b>	
FUNCTIONAL DESCRIPTION .....	12
ASSEMBLY .....	13-16
ATTACHING HANDLE .....	13
INSTALLING BEVEL KNOB .....	13
INSTALLING THE DUST BAG .....	14
STORING THE BLADE WRENCH .....	14
ASSEMBLING THE TABLE EXTENSIONS .....	14-15
ATTACHING THE VISE .....	15
MOUNTING THE SAW .....	15-16
LASER GUIDE .....	16-18
LASER SAFETY .....	16-17
ALIGNING THE LASER .....	17-18
OPERATING INSTRUCTIONS .....	18-25
ADJUSTING THE BLADE-TO-FENCE ANGLE .....	19
ADJUSTING THE BLADE-TO-BASE ANGLE .....	19-20
ADJUSTING THE BEVEL .....	20
OPERATING THE HANDLE LOCK .....	20-21

SAFE OPERATING POSITIONS .....	21
CHANGING THE BLADE .....	21-23
MAKING A MITER CUT .....	23
CUTTING BOWED MATERIAL .....	23
MAKING A BEVEL CUT .....	23
MAKING A COMPOUND CUT .....	23
CUTTING CROWN MOULDING, TRIMS AND BASEBOARDS .....	24-25

### SECTION FOUR

MAINTENANCE AND CLEANING .....	25-26
ACCESSORIES .....	26
SPECIFICATIONS .....	27

### SECTION FIVE

3 YEAR LIMITED WARRANTY .....	27-30
-------------------------------	-------

## CONGRATULATIONS!

Thanks for choosing this product. At Alltrade, our aim is to provide you with quality products at an affordable price, and we want you to be totally satisfied with your product and our Customer Service. If any help and advice is needed, please contact us at 1-800-590-3723. Properly cared for, this tool will give you many years of satisfaction.

## INTENDED USE

This product is intended for consumer use only. This tool is not designed for professional use. The power cord should only be used in grounded electrical outlets. Failure to use the proper power cords and/or extension cords may result in fire or possible damage to the Miter Saw.

## GENERAL SAFETY RULES – FOR ALL ELECTRIC POWER TOOLS

### **WARNING**

**READ AND UNDERSTAND ALL INSTRUCTIONS.** Failure to follow all instructions in this manual may result in severe personal injury or death. Keep this manual and refer to it for Safety Instructions, Operating Procedures and Warranty.

**SAVE THESE INSTRUCTIONS FOR FUTURE REFERENCE.**

## RECOGNIZE SAFETY SYMBOLS, WORDS AND LABELS

The safety instructions provided in this manual are not intended to cover all possible conditions and practices that may occur when operating, maintaining and cleaning power equipment.

Always use common sense and pay particular attention to all the **DANGER**, **WARNING**, **CAUTION** and **NOTE** statements of this manual.



This is the safety alert symbol. It is used to alert you to potential personal injury hazards. Obey all safety messages that follow this symbol to avoid possible injury or death.

### **DANGER**

**DANGER** indicates an imminently hazardous situation which, if not avoided, will result in death or serious injury.

### **WARNING**

**WARNING** indicates a potentially hazardous situation which, if not avoided, could result in death or serious injury.

### **CAUTION**

**CAUTION** indicates a potentially hazardous situation which, if not avoided, may result in minor or moderate injury.

### **CAUTION**

**CAUTION** used without the safety alert symbol indicates a potentially hazardous situation which, if not avoided, may result in property damage.

### **NOTE**

**NOTE** provides additional information that is useful for proper use and maintenance of this tool. If a **NOTE** is indicated make sure it is fully understood.

## IMPORTANT SAFEGUARDS

### **DANGER**

People with electronic devices, such as pacemakers, should consult their physician(s) before using this product. Operation of electrical equipment in close proximity to a heart pacemaker could cause interference or failure of the pacemaker.

**WARNING:** Some dust created by power sanding, sawing, grinding, drilling and other construction activities contains chemicals known to the State of California to cause cancer, birth defects or other reproductive harm.

Some examples of these chemicals are:

- Lead from lead-based paints.
- Crystalline silica from bricks and cement and other masonry products, and arsenic and chromium from chemically-treated lumber.

Your risk from these exposures varies, depending on how often you do this type of work. To reduce your exposure to these chemicals: work in a well ventilated area, and work with approved safety equipment, such as dust masks that are specially designed to filter out microscopic particles.

**WARNING:** Handling the power cord on corded products may expose you to lead, a chemical known to the State of California to cause cancer and birth defects or other reproductive harm. *Wash hands after handling.*

## WORK AREA

### **WARNING**

Keep your work area clean and well lit. Cluttered work benches and dark work areas may cause accidents or injury.

Do not operate power tools in explosive areas, such as in the presence of flammable liquids, gases or dust. Power tools create sparks which may ignite the dust or fumes.

Keep bystanders, children and visitors away while operating a power tool. Distractions can cause you to lose control.

## ELECTRICAL SAFETY

### WARNING

**This tool is equipped with an electric cord having an equipment-grounding conductor and a grounding plug. Grounded tools must be plugged into an outlet properly installed and grounded in accordance with all codes and ordinances.** Never remove the grounding prong or modify the plug in any way. Do not use any adaptor plugs. Check with a qualified electrician if you are in doubt as to whether the outlet is properly grounded. If the tools should electrically malfunction or break down, grounding provides a low resistance path to carry electricity away from the user.

**Avoid body contact with grounded surfaces such as pipes, radiators, ranges and refrigerators.** There is an increased risk of electric shock if your body is grounded.

**Do not expose power tools to rain or wet conditions.** Water entering a power tool will increase the risk of electric shock.

**Do not abuse the cord. Never use the cord to carry the tool or pull the plug from an outlet. Keep the cord away from heat, oil, sharp edges, or moving parts. Replace damaged cords immediately.** Damaged cords increase the risk of electric shock.

**When operating the tool outside, use an outdoor extension cord marked "W-A" or "W."** These cords are rated for outdoor use and reduce the risk of electric shock.

**Make sure the extension cord being used is in good condition.** If there are any cut or nicks (no matter how deep) in the insulation, **DO NOT** use that cord. Also, make sure the extension cord is heavy enough to carry the current needed by the saw (see ELECTRICAL REQUIREMENTS). **DO NOT** use small "around-the-house" lamp extension cords. These cords can easily overheat and/or catch fire when used with power tools.

## PERSONAL SAFETY

### WARNING

**Stay alert, watch what you are doing, and use common sense when operating a power tool. Do not use tool while tired or under the influence of drugs, alcohol or medication.** A moment of inattention while operating power tools may result in serious personal injury.

**Dress properly. Do not wear loose clothing or jewelry. Contain long hair. Keep your hair, clothing, and gloves away from moving parts.** Loose clothes, jewelry or long hair can be caught in moving parts.

### WARNING

**Avoid accidental starting. Be sure switch is off before plugging in.** Carrying tools with your finger on the switch or plugging in tools that have the switch on invites accidents.

**Remove adjusting keys or wrenches before turning the tool "ON".** A wrench or a key that is left attached to a rotating part of the tool may result in personal injury.

**Do not overreach. Keep proper footing and balance at all times.** Proper footing and balance enable better control of the tool in unexpected situations.

**Use safety equipment. Always wear eye protection.** Dust mask, non-skid safety shoes, hard hat, or hearing protection must be used for appropriate conditions.

## TOOL USE AND CARE

### CAUTION

**Use clamps or other practical ways to secure and support the workpiece to a stable platform.** Holding the work by hand or against your body is unstable and may lead to loss of control.

**Do not force tool. Use the correct tool for your application.** The correct tool will do the job better and safer at the rate for which it is designed.

**Do not use tool if the power switch does not turn it "ON" or "OFF".** Any tool that cannot be controlled with the power switch is dangerous and must be replaced.

**Disconnect the power cord plug from the power source before making any adjustments, changing accessories or storing the tool.** Such preventive safety measures reduce the risk of starting the tool accidentally.

**Store idle tools out of reach of children and other untrained persons.** Tools are dangerous in the hands of untrained users.

**Maintain tools with care. Keep cutting tools sharp and clean.** Properly maintained tools with a sharp cutting edge are less likely to bind and are easier to control.

**Check for misalignment or binding of moving parts, breakage of parts, and any other condition that may affect the tool's operation. If damaged, have the tool serviced before using.** Many accidents are caused by poorly maintained tools.

**Use only accessories that are recommended by the manufacturer for your model.** Accessories that may be suitable for one tool may become hazardous when used on another tool.

## SERVICE

**Tool service must be performed only by qualified repair personnel.** Service or maintenance by unqualified personnel may result in a risk of injury.

**When servicing a tool, use only identical replacement parts. Follow instructions in the Maintenance section of this manual.** Use of unauthorized parts or failure to follow Maintenance Instructions may create a risk of electric shock or injury.

### SPECIFIC SAFETY RULES AND/OR SYMBOLS

**⚠ CAUTION** Hold tool by insulated gripping surfaces when performing an operation where the cutting tool may contact hidden wiring or its own cord. Contact with a “live” wire will also make exposed metal parts of the tool “live” and shock the operator.

### IMPORTANT SAFETY RULES FOR MITER SAWS

#### ⚠ WARNING

**Avoid prolonged contact with dust created by the Miter Saw.** Allowing the dust to get into your mouth, eyes, or lay on your skin promotes the absorption of harmful chemicals into your body.

**Read and understand all instructions.** Failure to follow all instructions listed in this manual may result in property damage, damage to the tool, or serious personal injury or even death.

**Unpack the Miter Saw completely from its carton.** Inspect the saw and accessories and ensure they are free from defects or breakage due to shipping.

**Do not operate this Miter Saw until it is completely assembled according to the instructions in this manual.** Failure to adhere to these instructions could result in serious and/or permanent injury to the operator.

**Make sure approved eye protection is being worn and properly adjusted and secured at all times the Miter Saw is in use.** Everyday eyeglasses only have impact-resistant lenses and **ARE NOT** safety glasses. Safety glasses must conform to ANSI Z87.1 requirements. Approved safety glasses and goggles will have Z87 printed or stamped on them.

**Follow all wiring codes.** Use only properly grounded three-hole grounded receptacles. **DO NOT** cut the third prong off the power cord. When using an extension cord, use only UL Listed extension cords with minimum 16 AWG wiring and a maximum length of 25 feet.

#### ⚠ WARNING

**Keep bystanders, children, and visitors at a safe distance from the Miter Saw while it is in operation.** Distractions can cause inadvertent misuse resulting in possible injury to the bystanders or to the operator.

**Wear proper apparel.** Do not wear loose clothing, gloves, neckties, rings, bracelets, or other apparel that could possibly become caught in the moving parts of the Miter Saw. When working in a shop environment around power tools, wear nonslip footwear. Use protective hair covering to contain long hair.

**Keep the work area clean at all times.** Cluttered areas around the Miter Saw can cause unexpected accidents if the debris comes in contact with the moving parts of the Miter Saw.

**Maintain a proper work environment.** Do not operate the Miter Saw in damp or wet locations or expose it to rain. Water can cause the electrical components to malfunction resulting in damage to the Miter Saw and/or serious injury or death to the operator.

**Don't force the tool.** The Miter Saw will do a better job and be safer if cutting operations are performed at the proper speeds as expressed in this manual.

**Wear all necessary protective gear, including goggles, ear plugs and a dust mask.**

**Keep hands out of the path of the saw blade.**

**DO NOT operate saw without guards in place.**

**Do not stand directly in front of the Miter Saw.** Loose fragments could fly off at high speeds possibly causing injury.

**Properly support extra-long or extra-wide workpieces.** Workpieces that are too long or too wide can tip and cause the blade to seize resulting in a sudden kickback motion resulting in damage to the workpiece and Miter Saw as well as possible severe injury to the operator.

**Do not perform any operation freehand.** The workpiece must be tight against the fence to prevent the piece from moving while it is being cut. Keep the area between the saw and the workpiece free of debris. Clamp the workpiece if necessary.

**NEVER reach around the blade.**

**Turn tool off and wait for saw blade to stop before moving workpiece or changing settings.**

**Use 10" blades only. NEVER use blades above or below the rated blade diameter. NEVER use blades recommended for operation at less than 4800 RPM.**

**⚠ WARNING**

Release lower guard retraction mechanism after each cut and before moving or removing the workpiece.

Always keep arms, hands, and fingers away from the workpiece while it is on the table and the Miter Saw is turned on. Severe injury could result.

Always clamp the workpiece firmly against the work table. Never attempt to hold the workpiece by hand. The blade can seize in the workpiece causing it to spin rapidly. This will cause loss of control of the workpiece resulting in severe injuries or damage to the workpiece and Miter Saw.

**DO NOT** cut materials that could shatter or grab the blade.

Make sure the blade is loaded correctly. The arrow on the blade should point in the same direction as the arrow on the upper blade cover. Blade teeth should point downward.

Reduce the risk of unintentional starting. Ensure the "ON/OFF" switch is set to the "OFF" position before plugging the power cord into the AC outlet.

**NEVER** use a dull blade. Keep blade sharp and free from dents or damage.

Make sure the blade is properly aligned. Unplug the cord and use your hand to spin the blade. The blade should spin smoothly without making contact with any other part of the saw. If there is contact, realign the blade before using the saw.

Make sure the blade and blade guards are free from debris.

Make sure the blade guards are properly installed.

Check all screws and fastenings before use. Make sure the blade screw is tight and secure.

Cut only one piece of material at a time. Leave enough room for the waste piece to move once it is cut or it may become wedged against the blade and create a hazard.

Be extremely careful when cutting pieces that are very large, very small or oddly shaped. Make sure all oddly shaped pieces are held securely so they cannot slip or cause kickback. Moulding should be clamped down flat before cutting.

**DO NOT** let the workpiece sag or bend. If necessary, use tables or sawhorses to support the piece while cutting.

**NEVER** let your fingers get closer than 4" to the blade. You cannot cut any workpiece that requires you to get your hand closer than 4" to the blade.

**⚠ WARNING**

**NEVER** allow bystanders behind the saw or close enough to the workpiece to be hit by flying debris.

Round material such as dowel rods or tubing may roll when cut. Clamp securely before cutting.

Check that the workpiece is free of nails or other foreign objects.

Make sure ventilation slots are clear of dust or debris.

Mount the saw to a work bench or table before use to prevent unexpected saw movement. If the saw moves during use, it could cause injury to the operator and/or damage to the workpiece.

**NEVER** lubricate the blade while it is in motion.

Before moving the saw, make sure the cord is unplugged and the handle is locked in the down position. To avoid back injury, do not attempt to lift the saw by yourself.

Give the saw a test run before cutting. If the tool vibrates excessively or makes unusual noises, stop operating the saw immediately and correct the problem.

Make sure the blade is loaded correctly. The arrow on the blade should point in the same direction as the arrow on the upper blade cover. Blade teeth should point downward.

Never hold or clamp the waste portion of the material. Cutoff pieces must be free to move aside or they may wedge against the blade and cause injury to the operator or damage to the workpiece.

If the blade becomes clogged with debris, release the trigger switch and let the blade come to a complete stop before unplugging the tool and removing the debris.

After finishing a cut, release the trigger switch and allow the blade to come to a complete stop before raising the handle.

Make sure the blade is up to speed before lowering it into the workpiece.

Do not use this compound miter saw for cutting ferrous metals or steel.





Cutting non-ferrous metals can be dangerous. Follow all Safety instructions carefully.

Use only blades specifically made for cutting non-ferrous metal.

Non-ferrous metals should be cut only under the supervision of an experienced person.

## SYMBOLS

**IMPORTANT:** Some of the following symbols may be used on your tool. Please study them and learn their meaning. Proper interpretation of these symbols will allow you to operate the tool better and safer.

SYMBOL	NAME	EXPLANATION
V	Volts	Voltage (Potential)
A	Amperes	Current
Hz	Hertz	Frequency (Cycles per Second)
W	Watt	Power
Kg	Kilograms	Weight
	Alternating Current	Type of Current
	Direct Current	Type of Current
	Alternating or Direct Current	Type of Current
	Earthing Terminal	Grounding Terminal
	Class II Construction	Denotes Double Insulation
min	Minutes	Time
s	Seconds	Time
$\phi$	Diameter	Size of Drill Bits, Grinding Wheels, etc.
$n_0$	No-Load Speed	No-Load Rotational Speed
.../min	Revolutions per Minute	Revolutions, Surface Speed, Strokes, etc., per Minute
1,2,3, ...	Ring Selector Settings	Speed, Torque or Position Settings

## FUNCTIONAL DESCRIPTION

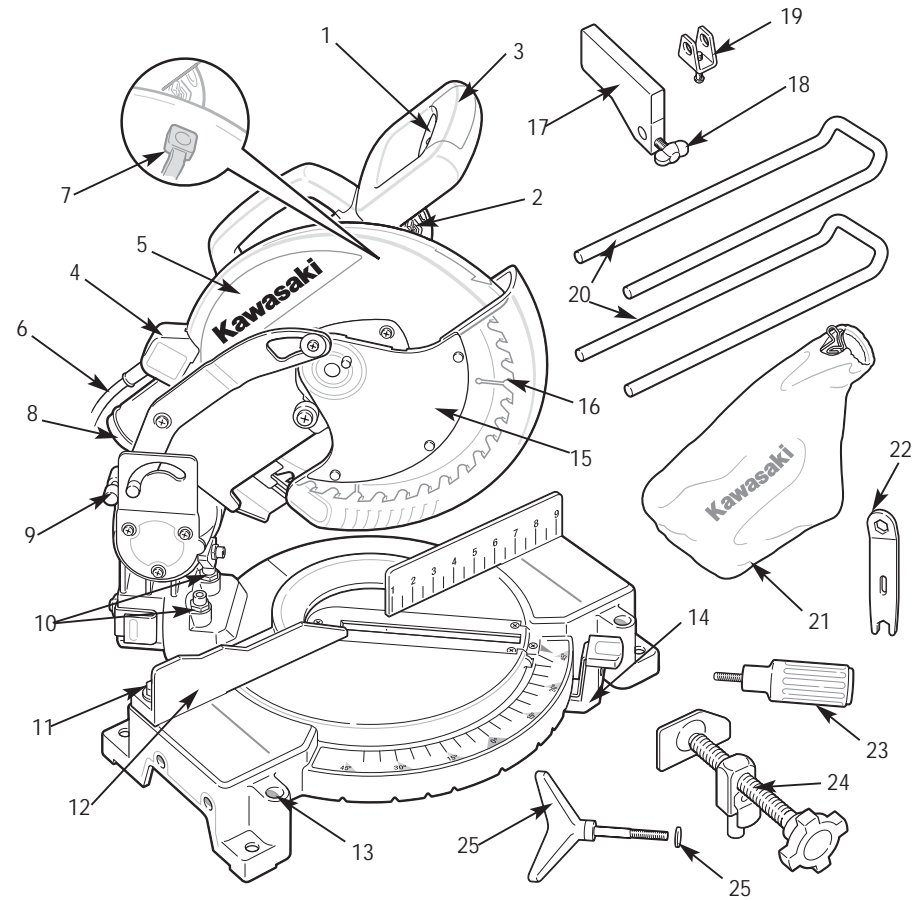

### CONTROLS AND COMPONENTS:

- |                              |                             |
|------------------------------|-----------------------------|
| 1. Trigger Switch            | 14. Miter Adjustment Button |
| 2. Laser Switch              | 15. Blade Guard             |
| 3. Main Handle               | 16. Lower Guard             |
| 4. Laser Case                | 17. Fence Bracket           |
| 5. Upper Guard               | 18. Wing Screw              |
| 6. Power Cord                | 19. Bar Clamps (4)          |
| 7. Arbor Lock                | 20. Table Extensions (2)    |
| 8. Dust Port                 | 21. Dust Bag                |
| 9. Handle Lock               | 22. Wrench                  |
| 10. Bevel Adjustment Hex Nut | 23. Adjustable Screw Handle |
| 11. Fence Adjustment Bolts   | 24. Vise                    |
| 12. Fence                    | 25. Bevel Knob and Washer   |
| 13. Vise Mounting Hole       |                             |

## ASSEMBLY

**⚠ WARNING** To prevent injury and/or property damage, **DO NOT** plug in the saw if any part is missing or damaged. Make sure all saw parts are present and undamaged before using this Miter Saw.

### ATTACHING HANDLE

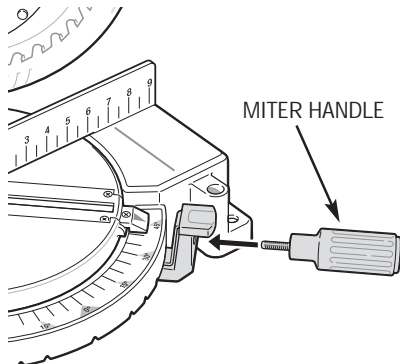

ATTACHING THE MITER HANDLE

1. Locate the handle hole in the front of the miter table.
2. Insert the screw end of the handle into the hole and turn clockwise until the handle is securely tightened.
3. To release the miter table from its set position, loosen the handle a quarter turn and press down on the miter handle release. To lock the table into place, tighten the handle.

### ATTACHING BEVEL KNOB

1. Slip washer over the screw on the bottom of the bevel knob and insert the screw into the hole at the rear of the saw.
2. Turn knob clockwise until tight.

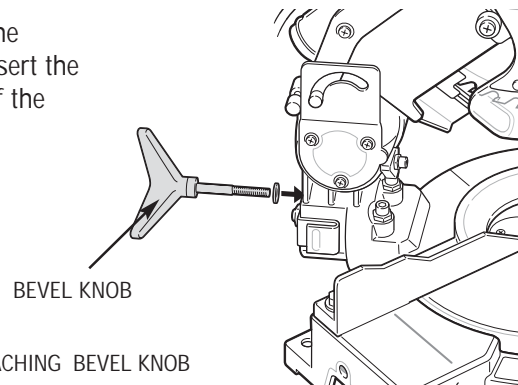

ATTACHING BEVEL KNOB

### INSTALLING THE DUST BAG

1. Squeeze the two tabs on the neck of the dust bag to open the spring clip wide enough to slip the dust bag opening over the rim of the dust port. Make sure the bag is pushed past the locking ridge.
2. Rotate the bag until the zipper is facing down.
3. Release the tabs.

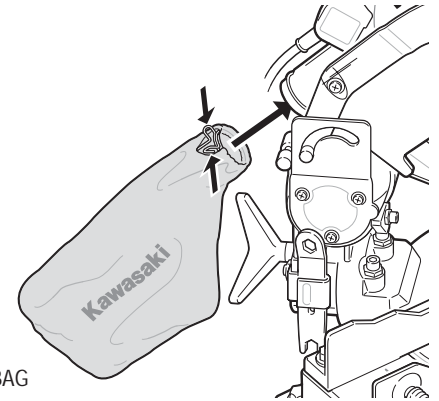

ATTACHING THE DUST BAG

### STORING BLADE WRENCH

To keep the blade wrench from being misplaced, slide it into the storage slot at the rear of the saw base.

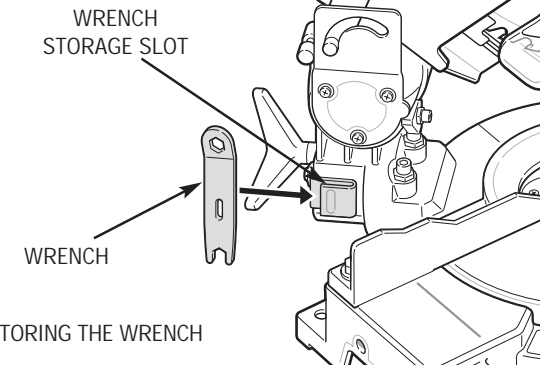

STORING THE WRENCH

### ASSEMBLING TABLE EXTENSIONS

1. Unplug the power cord.
2. Lock the saw handle and the miter table in the down position.
3. Tilt the saw back and fasten it securely in place to make sure that it will not fall forward or tip off the workbench while you are working underneath the base.
4. Slide the adjustable fence bracket onto the arm of the table extension. Screw the wing screw at the bottom of the bracket until the bracket remains firmly in place.
5. Insert the table extension into the first set of holes on the base. Make sure the fence bracket rests on top of the arms.
6. Slip a bar clamp over each arm, screw side out.



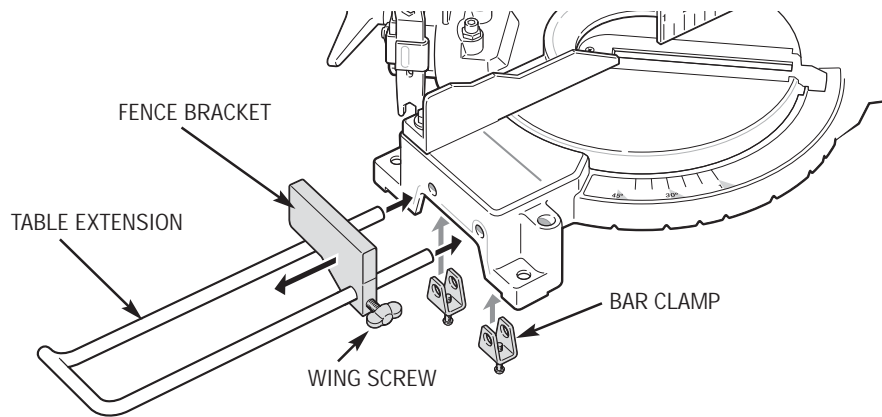

ASSEMBLING THE TABLE EXTENSIONS

7. Push the arms through the second set of holes until the ends touch the base of the saw.
8. Carefully tighten the bar clamp screws until the table extensions are held firmly in place. Turn the lock nuts clockwise to keep the screw from loosening.
9. Repeat Steps 4 through 8 for the table extension on the other side.
10. Unfasten the saw and carefully lower it down onto the workbench.

#### ATTACHING THE VISE

Position the grip-plate as shown and insert the vise inside the vise mounting hole.

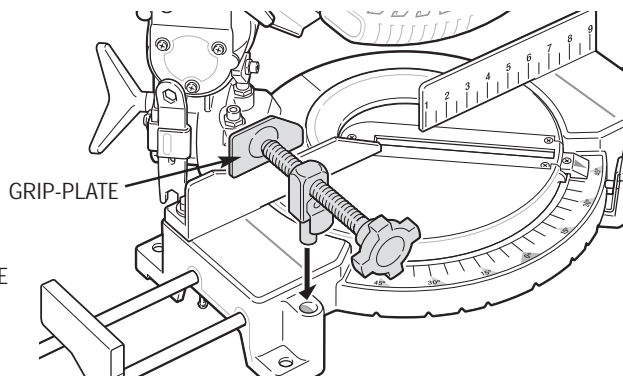

ATTACHING THE VISE

#### MOUNTING THE SAW

**The Miter Saw must be firmly mounted to a workbench or other sturdy work surface before use.** Once the mounting location is selected, attach the saw to the bench with wood screws.

**If a more portable mounting site is desired, the saw may be attached to a 3/4" piece of plywood.** Make sure all four mounting feet are securely anchored to the plywood. Before using saw, clamp the plywood to sawhorses or other stationary mounting surfaces. Make sure the location is firm and level and allows enough room to safely maneuver the workpiece.

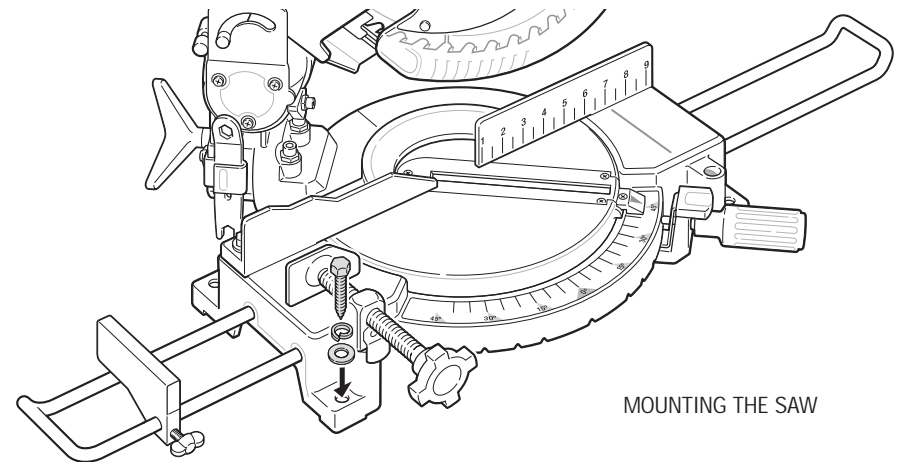

#### NOTE

Table extensions must be installed before mounting saw.

#### LASER GUIDE

#### CAUTION

Use of controls or procedures, or performance of procedures other than those specified herein may result in hazardous radiation exposure.

#### WARNING

**DO NOT** use the Miter Saw until it is securely mounted. An unmounted saw may shift or move unexpectedly during use, causing personal injury and/or property damage.

## LASER SAFETY

### **⚠ WARNING**

**NEVER LOOK INTO THE LASER BEAM.** Any contact with the eyes by the beam could cause injury. Do not use the laser when cutting reflective materials.

**DO NOT AIM THE LASER BEAM AT ANYONE OR AT REFLECTIVE SURFACES. CLASS 2M LASER PRODUCT.** Any contact with the eyes by the beam could cause injury. Ensure the laser beam is turned on only when the tool is on a non-reflective workpiece and as such it is aimed only at the work surface. Metals and other materials like steel which can be highly reflective should only be cut without the use of the laser.

**STORE OUT OF REACH OF CHILDREN.** Equipment should be in a high location or locked up to keep out of reach of children. It is not a toy.

**DO NOT TAMPER WITH THE LASER OUTPUT.** Changing the performance of the laser to increase its output is prohibited. Any claim for damages or injuries resulting from not following these instructions will be refused.

#### **OPERATION ACCESSIBLE FIELDS:**

Wavelength	636-660nm
Laser Power for Classification	<1mW CW

**NEVER OPERATE LASER IF THE UNIT IS DEFECTIVE OR THE COVER OR SEAL IS DAMAGED.**

**DO NOT SERVICE LASER.** The laser unit must be returned to the factory for any service or repair. Service or repair must be handled by authorized factory trained technicians.

Do not open the laser unit except to change batteries.

**REMOVE BATTERIES IF THE LEVEL IS TO BE STORED FOR ANY LENGTH OF TIME.** Batteries may leak and damage the laser if it is stored idle for more than 3 months.

Be careful with this tool. Striking or jarring it, especially on the laser housing, can affect its accuracy.

Other than batteries, there are no user-serviceable parts in the laser device.

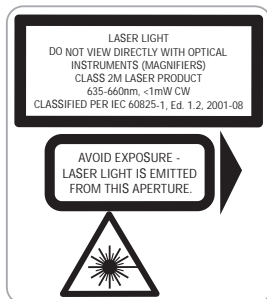

LASER RADIATION  
CAUTION LABEL

## ALIGNING THE LASER

The laser must be aligned with the blade before use. If the laser is not aligned properly, your cuts will not be accurate.

#### **TO ALIGN THE LASER:**

1. The trigger switch and the laser switch must be in the OFF position.
2. Put a padlock or screwdriver through the hole in the trigger switch to make sure the blade cannot be started accidentally.
3. Plug in the power cord.
4. Turn on the laser switch.
5. Loosen the laser cover screws and pull off the laser cover, leaving the screws in place.
6. Loosen the screws on the laser unit until it can be moved easily.
7. Align the laser light line with either the left or right side of the blade. Make sure the light is right against the blade. Extra space between the laser line and the blade will lead to inaccurate cutting.
8. Once the laser light line is properly positioned, tighten the laser unit screws.
9. Push the laser cover back into place and tighten the laser cover screws.

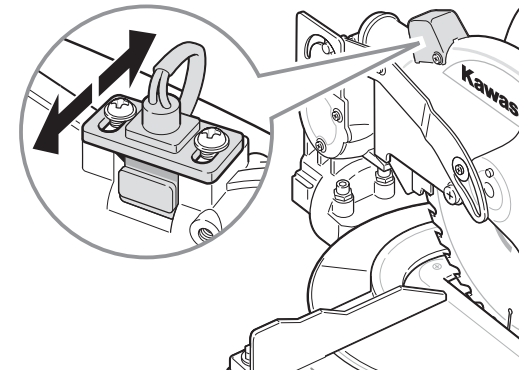

ALIGNING THE LASER

### **NOTE**

Laser light should be kept OFF when not in use.

## OPERATING INSTRUCTIONS FOR THE MITER SAW

### **⚠ WARNING**

Do not use the Miter Saw if the power cord (or extension cord, if used) is worn, cut, or damaged in any other way. A worn or damaged power cord must be replaced immediately. Contact Alltrade Customer Service to obtain the proper replacement power cord. Failure to adhere to this warning could result in damage to the Miter Saw motor, fire, or severe electrical shock or even death to the operator.

## ADJUSTING THE BLADE-TO-FENCE ANGLE

### TO MAKE SURE THE BLADE IS SQUARE TO THE FENCE:

1. Turn the blade until it is at the 0° marker and lock the handle down.
2. Place a combination square (not included) flat against the fence and close to but not touching the blade. **DO NOT** touch the saw teeth with the square.
3. The square should contact the entire length of both the square and the blade.

### IF THE BLADE DOES NOT MAKE FULL CONTACT WITH THE SQUARE:

1. Use a 9/16" wrench (not included) to loosen the four fence adjustment screws.
2. Hold the square against the blade, taking care not to touch the saw teeth.
3. Move the fence until it makes full contact with the square.
4. Hold the fence in place and tighten the fence adjustment bolts.

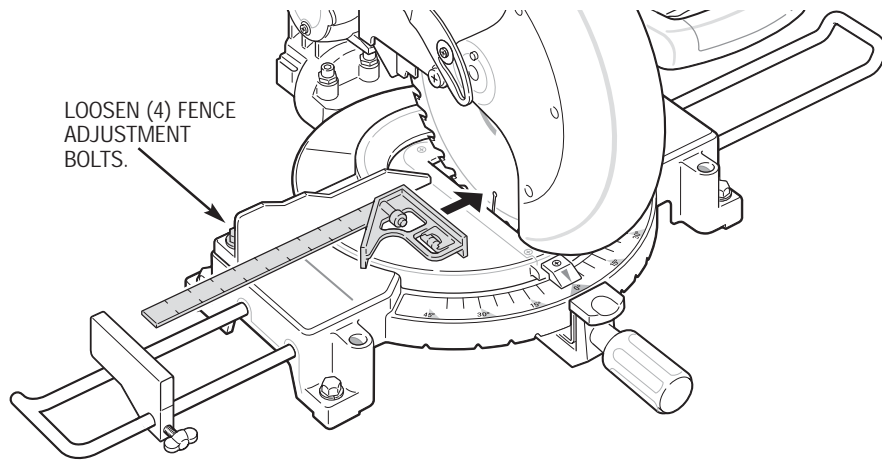

ADJUSTING THE BLADE-TO-FENCE ANGLE

## ADJUSTING THE BLADE-TO-BASE ANGLE

### TO MAKE SURE THE BLADE IS PERPENDICULAR TO THE BASE:

1. Set a combination square (not included) flat against the base of the saw.
2. Lower the blade. **DO NOT** touch the saw teeth with the square.
3. The square should contact the entire length of both the square and the blade.

### IF THE BLADE DOES NOT MAKE FULL CONTACT WITH THE SQUARE:

1. Loosen the bevel adjustment hex nut.
2. Turn the bevel adjustment screw up or down until the blade is completely flat against the square.

3. Tighten the locknut on the bevel adjustment screw.

### TO ALIGN THE BEVEL INDICATOR:

1. Loosen the locknut and adjust the bevel indicator up or down until it aligns with the 0° mark.
2. Tighten the locknut.

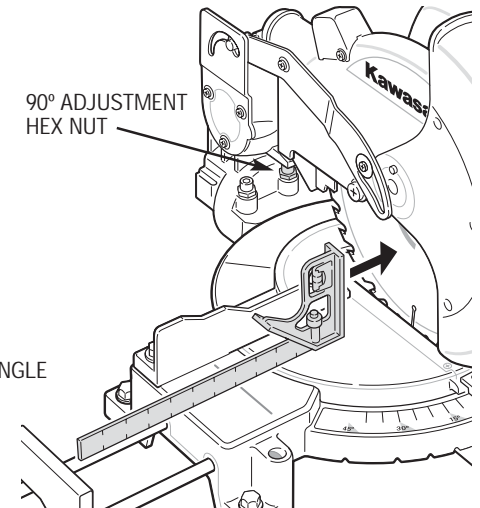

ADJUSTING THE BLADE-TO-BASE ANGLE

## ADJUSTING THE BEVEL

When the handle assembly is against the bevel hex nut, the bevel indicator should be at the 45° mark.

### TO ADJUST THE BEVEL:

1. Loosen the bevel stop hex nut.
2. Use a 10mm wrench to turn the bevel stop screw up or down until the bevel indicator reaches the 45° mark.
3. Retighten the locknut.

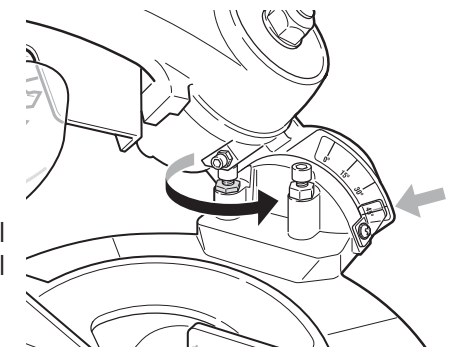

ADJUSTING THE BEVEL

## OPERATING THE HANDLE LOCK

**CAUTION** Saw should never be operated while the blade is locked in the down position. Handle should only be locked for moving and storage.

### TO LOCK:

1. Push the handle down as far as possible.
2. Push in the handle lock.

### TO UNLOCK:

1. Push down on the saw handle.
2. Pull out the handle lock.
3. Release the handle and let the saw rise up to the operating position.

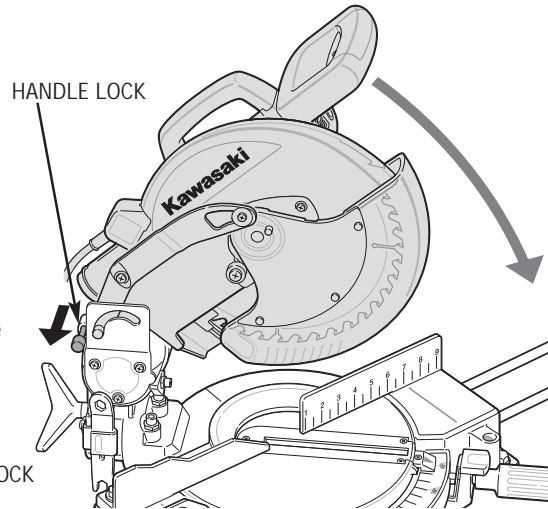

### SAFE OPERATING POSITIONS

#### **WARNING**

Never cut any workpiece that is so small you cannot keep your hands a safe distance from the blade.

Never stand directly behind the Miter Saw. Keep your face and body out of the path of flying debris.

Keep balanced at all times. Do not reach in front of the blade.

Keep workpiece pressed against the fence while cutting. Do not move your hand until after the trigger is released and the blade has stopped spinning.

Before cutting, double-check your proposed cutting path by making a dry run with the power turned off or by checking the blade path with the laser.

Never let long workpieces sag. This could cause the saw to catch and kick back. Long workpieces should be supported by the table extensions or other appropriate means.

Make sure the bevel adjustment knob and the bevel stop are both securely tightened before using the saw.

### CHANGING THE BLADE

#### **WARNING**

Carbide-tipped blades are very brittle and can be easily bent or broken. NEVER use a blade that has bent, broken, missing or loose carbide tips. Damaged tips can cause personal injury.

If a saw blade shows signs of wear or damage, replace it immediately. Dull or damaged saw blades are not safe and may cause personal injury.

**ALWAYS** make sure the saw is unplugged and the blade stopped before changing blades.

**NEVER** use a blade larger than 10" in diameter.

### TO CHANGE THE BLADE:

1. Make sure the saw is in the up position.
2. Remove the three mounting screws (as indicated by arrows) and remove the lower guard.
3. Push in on the arbor lock to keep the blade from spinning and use the socket wrench (included with the saw) to turn the arbor screw clockwise.

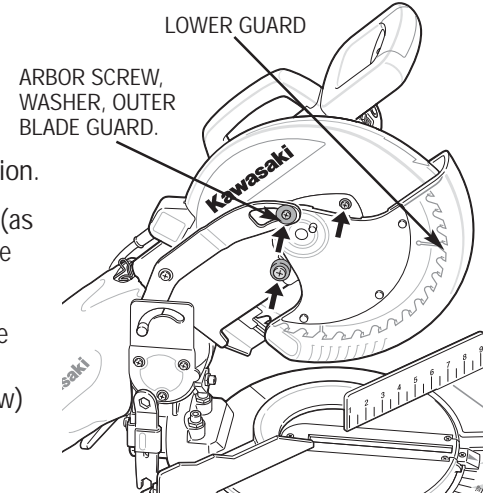

CHANGING THE BLADE

4. Remove the arbor screw, washer, outer blade guard and blade. Leave inner blade guard in place.
5. Clean area thoroughly, removing all dust particles and debris before replacing blade.

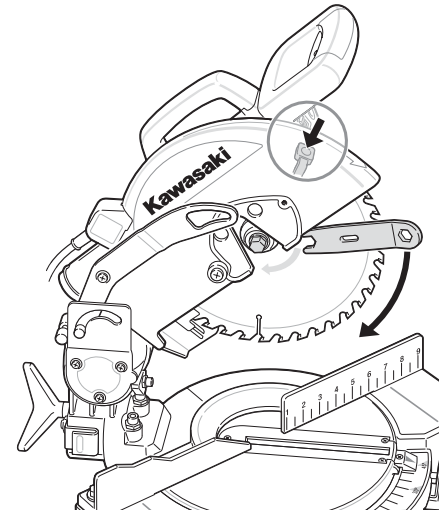

CHANGING THE BLADE

6. Make sure the new blade is 10" (25.4cm) in diameter.
7. Slide the blade into place, making sure that the arrow on the blade matches the direction of the arrow on the upper blade guard.

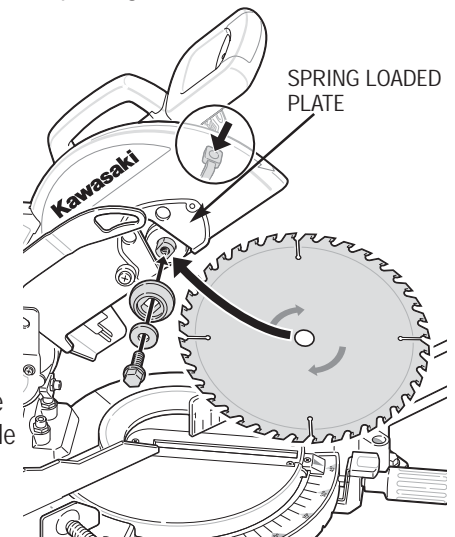

8. Replace the outer blade guard, the washer and the arbor screw. Push in on the arbor lock and turn the arbor screw counter-clockwise until tight.
9. Return the Lower Guard to its location as in step 1.
10. Turn the spring loaded mounting plate until its two mounting holes are lined up with the holes on the Upper Guard.
11. Secure the Lower Guard with the three mounting screws that were removed in step 2.

### MAKING A MITER CUT

1. Turn the miter handle counter-clockwise to unlock.
2. Press down on the thumb tab above the handle and turn the miter table to the angle desired.
3. Release the thumb tab and tighten the handle to lock the table into position.
4. **Before cutting, position your body out of the line of flying debris. Never stand in front of the saw.**

### CUTTING BOWED MATERIAL

**⚠ WARNING** Cutting a bowed piece of material incorrectly could lead to kickback and serious personal injury.

Always inspect your workpiece before cutting. If the material is bowed, make sure the bowed portion points down when you are cutting.

### MAKING A BEVEL CUT

1. Loosen the bevel lock knob.
2. Tilt the blade to the desired angle.
3. Tighten the bevel lock knob.
4. Stand to the left of the handle while making the cut.

### MAKING A COMPOUND CUT

1. Loosen the bevel lock knob, tilt the blade to the desired angle and tighten the bevel lock knob.
2. Loosen the miter handle, press down the thumb tab and move the miter table to the angle you need. Tighten the miter handle to keep it in place.
3. Keep your body in line with the handle while making the cut.

### CUTTING CROWN MOULDING, TRIMS AND BASEBOARDS

Cutting crown moulding, trims and baseboards must be done very accurately. If the angles are not correct, the mouldings will not fit flush with the wall, the ceiling or each other.

**NOTE** Always practice on scrap material before attempting to cut the final workpiece.

### BASEBOARDS

1. To prevent damaging the surface of the moulding, tape all contact areas before clamping.
2. Make sure workpiece lies flat against the miter table with one edge pressed firmly against the fence.
3. Clamp into place with C-clamps or vise clamps.
4. To avoid splintering, place tape over the area to be cut.
5. Mark the cut line on the tape.
6. Make sure you have the right type of blade for the project. If the blade type is not correct, the moulding may break or splinter.

### CROWN MOULDING

When cutting crown moulding, use extreme care to get the cut surfaces angled correctly. When two cut pieces come together, they should make a 90° angle.

1. To prevent damaging the surface of the moulding, tape all contact areas before clamping.
2. Lay moulding down on the widest part of the back. Make sure workpiece lies flat against the miter table with one edge pressed firmly against the fence.
3. Clamp into place with C-clamps or vise clamps.
4. To avoid splintering, place tape over the area to be cut.
5. Mark the cut line on the tape.
6. Make sure you have the right type of blade for the project. If the blade type is not correct, the moulding may break or splinter.
7. Remember that the angle settings for two adjoining pieces of moulding are dependent on each other. If you change the angle of one side, you must also change the angle of the corresponding side. For instance, if you subtract 5° from the left side, you must add 5° to the right side.
8. Always practice on scrap material to make sure the angles are correct before attempting to cut the final workpiece.

### WHEN CUTTING ANGLES FOR AN INSIDE CORNER:

#### Left side

1. Set bevel at 33.9°.
2. Set miter at RIGHT 31.6°.
3. Place the TOP of the moulding against the fence.
4. The finished side is the LEFT side of the cut piece.

#### Right side

1. Set bevel at 33.9°.
2. Set miter at LEFT 31.6°.
3. Place the BOTTOM of the moulding against the fence.
4. The finished side is the LEFT side of the cut piece.

### WHEN CUTTING ANGLES FOR AN OUTSIDE CORNER:

#### Left side

1. Set bevel at 33.9°.
2. Set miter at LEFT 31.6°.
3. Place the BOTTOM of the moulding against the fence.
4. The finished side is the RIGHT side of the cut piece.

#### Right side

1. Set bevel at 33.9°.
2. Set miter at RIGHT 31.6°.
3. Place the TOP of the moulding against the fence.
4. The finished side is the RIGHT side of the cut piece.

### MAINTENANCE AND CLEANING

**⚠ WARNING** Disconnect the Miter Saw from the AC power source before attempting any cleaning or maintenance.

Use only factory replacement parts. Using other replacement parts may cause electrical shock, fire or injury.

Replace cut, worn or damaged power cords immediately.

**ALWAYS** wear eye protection when blowing sawdust off your saw. Particles could fly up into your eyes.

**DO NOT** let sawdust pile up under or around your saw. Vacuum or use compressed air to keep the area clean.

Empty the sawdust bag frequently.

Make sure the lower blade guard is operating properly before each use. If the lower blade guard is damaged or missing, do not use your saw.

#### NOTE

Never use solvent or harsh detergents to clean the lower blade guard. Solvent will damage the plastic. Clean with a damp cloth only.

### TO CLEAN LASER UNIT:

1. Make sure the laser and saw switches are turned OFF and unplug the saw.
2. Pull off laser cover.
3. Remove the two screws and washers holding the laser unit to the saw.
4. Lift out laser unit.
5. Dust the laser unit with a very soft clean cloth or blow clean with gentle puffs of compressed air.
6. Put the laser unit back into place and realign the laser with the blade.
7. Push laser cover back into place.

This tool does not require lubrication. All ball bearings are permanently lubricated at the factory.

### ACCESSORIES

**Always attach grounded (3-prong) extension cords to grounded (3-hole) outlets. If the Miter Saw must be used outside, use an extension cord labeled “W-A” or “W”.** These extension cords are rated for outdoor use and reduce the chances of electrical shock.

**If you must use an extension cord, be sure that the gauge is large enough to carry the amount of current necessary for your power tool.** If not, your tool may experience a loss of power, excessive voltage drop or overheating. The smaller the gauge number, the heavier the cord (see table below).

### RECOMMENDED SIZES OF EXTENSION CORDS FOR 120 VOLT AC 60 HZ TOOLS

TOOL CURRENT RATING	CONDUCTOR SIZE IN A.W.G.			
	10 FT.	25 FT.	50 FT.	100 FT.
3-6	18	18	18	18
6-8	18	18	18	16
8-10	18	18	18	14
10-12	16	16	14	14
12-16	14	12	12	-
16-20	12	12	12	-

## SPECIFICATIONS

### SPECIFICATIONS

Voltage	120V  60 Hz
Rated Current	15A
No-Load Speed	5500 RPM
Maximum Horsepower	2.45 HP
Table Tilting Range:	0-45° (Left or Right)
Saw Body Tilting Range:	0-45° (Left)
Max Cut at:	45° (Left ):1-7/8"(H)X3-7/8"(W) 0° (Upright):2-1/8"(H)X3-3/8"(W)

## 3 YEAR LIMITED WARRANTY

### Express and Exclusive Limited Warranty to Original Retail Buyer

Alltrade Tools LLC (hereinafter "Alltrade") expressly warrants to the original retail purchaser of the accompanying KAWASAKI™ power tool and no one else all parts of the product (except those parts referred to below which are specifically excluded from such warranty (see Exclusions)) to be free from defects in materials and workmanship for a period of three years from original date of purchase, except that such warranty with regard to the battery shall be for a period of two years from original date of purchase, unless the tool is used for commercial or rental purposes.

**SPECIAL WARRANTY NOTE FOR COMMERCIAL OR RENTAL USE:** The above warranty for this Kawasaki™ power tool, including the battery, shall be effective for only 90 days from the original date of purchase if this tool is used for any **COMMERCIAL OR RENTAL PURPOSE.**

The date of purchase shall be the date of shipment to the original purchaser, or the date the original purchaser took possession, custody or control of the product, whichever occurred first. This warranty shall be null and void if the product or any component thereof is modified or altered. This warranty does not apply to any other product and/or component thereof manufactured or distributed by Alltrade, and does not apply to products and/or components thereof designed, manufactured and/or assembled by others, for which Alltrade makes no warranties whatsoever.

**THERE ARE NO WARRANTIES WHICH EXTEND BEYOND THE DESCRIPTION ON THE FACE HEREOF.**

### Warranty Performance

By purchasing the product, purchaser expressly acknowledges and agrees that their sole and exclusive remedy under this warranty shall be strictly limited to the repair or replacement of any covered nonconforming items or parts thereof provided that

any such nonconforming item and/or part is promptly returned to Alltrade's facility postage pre-paid and insured (address: ALLTRADE Warranty Claims & Repair, 1431 Via Plata, Long Beach, CA 90810, Attn: Customer Service #1-800-590-3723) within the applicable warranty period, with a written request by purchaser that Alltrade repair and/or replace the nonconforming item and/or part. We recommend that you keep the original product packaging in the event you need to ship the unit. We suggest the package be insured against loss or in transit damage. When sending your product include your name, address, phone number, dated proof of purchase (or copy), and a statement about the nature of problem. Warranty coverage is conditioned upon purchaser furnishing Alltrade with adequate written proof that they are the original purchaser and of the original purchase date. Parts returned, freight prepaid and insured, to Alltrade's facility (see above address) will be inspected and, at Alltrade's option, repaired and/or replaced free of charge if found to be defective and subject to warranty. Alltrade retains the sole discretion to determine whether any item or part is nonconforming and, if so, whether the item and/or part will be repaired and/or replaced. If the unit is repaired, new or reconditioned replacement parts may be used. If Alltrade chooses to replace the product, it may replace it with a new or reconditioned one of the same or comparable design. The repaired or replaced unit will be warranted under the terms of the remainder of the warranty period. Typically, a defective product that is returned within the first 30 days after the purchase date will be replaced; for items returned after the first 30 days and within the warranty period, covered defective parts not subject to normal wear and tear or other exclusions will be repaired or replaced, at Alltrade's option. During the warranty period, Alltrade will be responsible for the return shipping charges. Alltrade's repair and/or replacement of any nonconforming item and/or part thereof shall constitute fulfillment of all obligations to the purchaser. Alltrade shall not be responsible or liable for any expense, including freight charges, or repairs made outside Alltrade's facility, unless expressly agreed to by Alltrade in writing. Under no circumstances shall Alltrade bear any responsibility for loss of the unit, loss of time or rental, inconvenience, commercial loss or consequential damages.

### Exclusions

This warranty does not cover parts damaged due to normal wear, abnormal conditions, misapplication, misuse, abuse, accidents, operation at other than recommended pressures or temperatures, improper storage or freight damage. Parts damaged or worn by operation in dusty environments are not warranted. Failure to follow recommended operating and maintenance procedures also voids warranty.

This limited warranty does not apply to accessory items such as drill bits, screwdriving bits, circular saw blades, jigsaw blades, grinding wheels, sanding sheets and other related items.

DAMAGE TO THE PRODUCT RESULTING FROM TAMPERING, ACCIDENT, ABUSE, NEGLIGENCE, FAILURE TO FOLLOW INSTRUCTIONS, UNAUTHORIZED REPAIRS OR ALTERATIONS, DAMAGE WHILE IN TRANSIT TO OUR SERVICE FACILITY, USE OF UNAPPROVED OR IMPROPER ATTACHMENTS OR ACCESSORIES, COMMERCIAL AND RENTAL APPLICATIONS OR OTHER CAUSES UNRELATED TO PROBLEMS WITH MATERIAL OR WORKMANSHIP ARE NOT COVERED BY THIS WARRANTY.

Alltrade will not be liable for the following: labor charges, loss or damage resulting from improper operation, maintenance or repairs made by other persons; pre-delivery services such as assembly, oil or lubricants, and adjustment; maintenance services that are normally required to maintain the product.

The use of other than genuine Alltrade Repair Parts will void warranty.

#### **Warranty Disclaimers**

EXCLUSION AND DISCLAIMER OF ALL OTHER EXPRESS WARRANTIES, GUARANTIES AND/OR REPRESENTATIONS. EXCEPT FOR THE LIMITED WARRANTY PROVIDED ABOVE, ALL OTHER EXPRESS WARRANTIES, GUARANTIES AND/OR REPRESENTATIONS BY ALLTRADE AND/OR ITS REPRESENTATIVE(S) REGARDING THE DESIGN, MANUFACTURE, PURCHASE, USE AND/OR OPERATION OF THE PRODUCT OR ANY COMPONENT THEREOF SOLD HEREUNDER, REGARDLESS OF WHETHER ANY SUCH WARRANTY, GUARANTY AND/OR REPRESENTATION, WRITTEN OR ORAL, ARISES BY OPERATION OF LAW AND/OR EQUITY AND/OR BY ANY ACT OR OMISSION OF ALLTRADE AND/OR ITS REPRESENTATIVE(S), OR THE BUYER, ARE HEREBY EXPRESSLY EXCLUDED AND DISCLAIMED BY ALLTRADE AND/OR ITS REPRESENTATIVES. PURCHASER KNOWINGLY AND WILLINGLY WAIVES ANY AND ALL SUCH WARRANTIES AND RIGHTS, CLAIMS AND/OR CAUSES OF ACTION ARISING THEREFROM OR BASED THEREON. PURCHASER'S SOLE AND EXCLUSIVE REMEDY IS AS STATED ABOVE.

EXCLUSION AND DISCLAIMER OF ALL IMPLIED WARRANTIES, INCLUDING THE IMPLIED WARRANTIES OF MERCHANTABILITY AND FITNESS FOR A PARTICULAR PURPOSE. NO WARRANTY, ORAL OR WRITTEN, OTHER THAN THE ABOVE WARRANTY IS MADE WITH REGARD TO THIS PRODUCT. ALL EXPRESS AND/OR IMPLIED WARRANTIES, GUARANTIES AND/OR REPRESENTATIONS BY ALLTRADE AND/OR ITS REPRESENTATIVE(S) REGARDING THE DESIGN, MANUFACTURE, PURCHASE, USE AND/OR OPERATION OF THE PRODUCT OR ANY COMPONENT THEREOF SOLD HEREUNDER, REGARDLESS OF WHETHER ANY SUCH WARRANTY, GUARANTY AND/OR REPRESENTATION, WRITTEN OR ORAL, ARISES BY OPERATION OF LAW AND/OR EQUITY AND/OR BY ANY ACT OR OMISSION OF ALLTRADE AND/OR ITS REPRESENTATIVE(S), OR THE PURCHASER, INCLUDING BUT NOT LIMITED TO THE IMPLIED WARRANTY OF MERCHANTABILITY AND THE WARRANTY OF FITNESS FOR A PARTICULAR PURPOSE, ARE HEREBY EXPRESSLY EXCLUDED AND DISCLAIMED BY ALLTRADE AND/OR ITS REPRESENTATIVES.

PURCHASER KNOWINGLY AND WILLINGLY WAIVES ANY AND ALL SUCH WARRANTIES AND RIGHTS, CLAIMS AND/OR CAUSES OF ACTION ARISING THEREFROM OR BASED THEREON. PURCHASER'S SOLE AND EXCLUSIVE REMEDY IS AS STATED ABOVE.

#### **Limitation Of Liability**

IN NO EVENT SHALL ALLTRADE AND/OR ITS REPRESENTATIVE(S) BE LIABLE FOR INDIRECT, INCIDENTAL, SPECIAL AND/OR CONSEQUENTIAL DAMAGES OF ANY KIND ARISING OUT OF OR RELATED TO, DIRECTLY OR INDIRECTLY, ANY BREACH OF ANY PROVISION OF ANY AGREEMENT BETWEEN ALLTRADE AND/OR ITS REPRESENTATIVE(S) AND PURCHASER, ANY WARRANTY HEREUNDER, AND/OR THE EXISTENCE, DESIGN, MANUFACTURE, PURCHASE, USE AND/OR OPERATION OF ANY ITEM(S) SOLD HEREUNDER EVEN IF ALLTRADE AND/OR ITS REPRESENTATIVE(S) HAS BEEN ADVISED OF THE POSSIBILITY OF ANY SUCH DAMAGES. IN NO EVENT, WHETHER AS A RESULT OF A BREACH OF CONTRACT, WARRANTY, TORT (INCLUDING NEGLIGENCE) OR OTHERWISE, SHALL ALLTRADE'S AND/OR ITS REPRESENTATIVE(S)' LIABILITY EXCEED THE PRICE OF THE PRODUCT. ANY AND ALL LIABILITY CONNECTED WITH THE USE OF THIS PRODUCT SHALL TERMINATE UPON THE EXPIRATION OF THE WARRANTY PERIODS SPECIFIED ABOVE.

#### **Limitations on Warranty Disclaimers**

Some states do not allow limitations on how long an implied warranty lasts and some states do not allow the exclusion or limitation of the incidental or consequential damages, so part or all of the above limitations or exclusions may not apply to you. This warranty gives you specific legal rights, and you may also have other rights which vary from state to state.

If your product is not covered by this warranty, please call our Customer Service Department toll free at 1-800-590-3723 for general repair information and charges.